

USR-C215 User Manual

File Version: V1.0



Contents

1. Quick Start.....	4
1.1. Hardware Testing Environment.....	4
1.2. Data Transmission Testing.....	5
2. Overview.....	6
2.1. Brief Introduction.....	6
2.2. Features.....	6
2.3. Parameters.....	6
3. Hardware.....	7
3.1. Hardware Information.....	7
3.1.1. Dimensions.....	7
3.1.2. Pin Defination.....	7
3.1.3. Antenna.....	8
3.1.4. Evaluation kit.....	8
3.2. Hardware Reference Design.....	9
3.2.1. Typical Application Connection.....	9
3.2.2. Power Interface.....	9
3.2.3. UART Interface.....	10
3.2.4. Reset & Reload.....	10
4. Module Function.....	11
4.1. Wireless Network Mode.....	11
4.1.1. Work as STA.....	11
4.1.2. Work as AP.....	12
4.1.3. Work as AP+STA.....	12
4.1.4. Encryption Type.....	12
4.2. Work Mode.....	13
4.2.1. Transparent Transmission Mode.....	13
4.2.1.1. Short Description.....	13
4.2.1.2. UART Frame.....	13
4.2.2. Command Mode.....	14
4.3. Socket Connection.....	14
4.4. Search in LAN.....	15
4.5. Registration Packet Mechanism.....	15
4.6. Usrlink (Fast Networking Protocol).....	15
4.7. Simplelink.....	17
4.8. Class RFC2217.....	18
5. Setting Method.....	19
5.1. Webpage.....	19
5.1.1. WiFi Parameter Setting.....	20
5.1.2. Transparent Transmission Parameter Setting.....	21
5.1.3. Extra Function.....	22
5.1.4. System Setting.....	23
5.1.5. About USR.....	24

5.2. AT Command Instructions.....	24
5.2.1. AT Command Description.....	25
5.3. AT Instruction Set.....	26
5.3.1. AT Command List.....	26
5.3.1.1. AT+E.....	27
5.3.1.2. AT+WMODE.....	27
5.3.1.3. AT+ENTM.....	28
5.3.1.4. AT+MID.....	28
5.3.1.5. AT+RELD.....	28
5.3.1.6. AT+Z.....	28
5.3.1.7. AT+H (not available now).....	29
5.3.1.8. AT+CFGTF.....	29
5.3.1.9. AT+UART.....	29
5.3.1.10. AT+UARTTE.....	30
5.3.1.11. AT+NETP.....	30
5.3.1.12. AT+TCPLK.....	31
5.3.1.13. AT+TCPDIS.....	31
5.3.1.14. AT+SOCKB.....	31
5.3.1.15. AT+TCPDISB.....	32
5.3.1.16. AT+TCPLKB.....	32
5.3.1.17. AT+WSSSID.....	32
5.3.1.18. AT+WSKEY.....	33
5.3.1.19. AT+WANN.....	33
5.3.1.20. AT+WSMAC.....	34
5.3.1.21. AT+WSLK.....	34
5.3.1.22. AT+WSLQ.....	34
5.3.1.23. AT+WSCAN.....	35
5.3.1.24. AT+WSDNS.....	35
5.3.1.25. AT+LANN.....	35
5.3.1.26. AT+WAP.....	36
5.3.1.27. AT+WAKEY.....	36
5.3.1.28. AT+WALK.....	36
5.3.1.29. AT+PLANG.....	37
5.3.1.30. AT+DTDDIS.....	37
5.3.1.31. AT+DTDID.....	37
5.3.1.32. AT+WRMID.....	38
5.3.1.33. AT+ASWD.....	38
5.3.1.34. AT+SMTLK.....	38
5.3.1.35. AT+USERVER.....	38
5.3.1.36. AT+RPTMAC.....	39
5.3.1.37. AT+WRRPTMAC.....	39
6. Contact Us.....	40
7. Disclaimer.....	40
8. Update History.....	40

1. Quick Start

USR-C215 is a cost effective serial to WiFi module, which allows almost any serial devices to be connected to a new or existing WiFi network, realize the two-way data transparent transmission between UART and WiFi network interface.

This chapter aims at getting start USR-C215 quickly. It's recommended that user read this chapter systemically and operate it according to instructions to make a scientific knowledge. Following chapter will introduce specific details, user can read interested chapter according to need.

If you have any question, feed it back to customer center please: <http://h.usriot.com>

1.1. Hardware Testing Environment

For quick testing, our evaluation kit is recommended. Testing steps as follows:

1. Hardware connection: Connect the module with PC by serial cable, power on, the Ready indicator will be on.

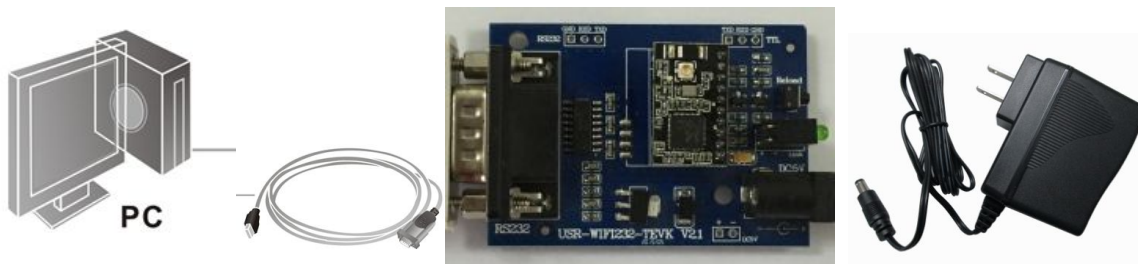

2. Wi-Fi connection: Open Wi-Fi on your PC, scan and join the module network: USR-C215.



1.2. Data Transmission Testing

We supply testing software “USR-TCP232-Test.exe”, pls download from this link:

<http://www.usriot.com/usr-tcp-test-v1-3/>

Module default parameters:

- SSID: USR-C215
- Encryption type: open, none
- UART settings: 115200, 8, 1, N
- Net settings: TCP, Server, 8899, 10.10.100.254
- IP address of module: 10.10.100.254

Steps for UART to Wi-Fi data transmission:

1. Open “USR-TCP232-Test.exe”, on the left is COM part, on the right is Net part.
2. UART settings: UART settings should be the same with module, that is : 115200, N, 8, 1
3. Click Open to open the serial port.
4. Socket connection: Module default setting is TCP Server, so we should select TCP Client as protocol. Server IP and Port is module IP and Port: 10.10.100.254; 8899.
5. Click Connect to establish TCP connection
6. Now we can realize data transmission between UART and WiFi.

The flow direction from UART to Net: COM of PC--> COM of module--> WiFi of module--> Net of PC.

The flow direction from Net to UART: Net of PC--> WiFi of module--> COM of module--> COM of PC.

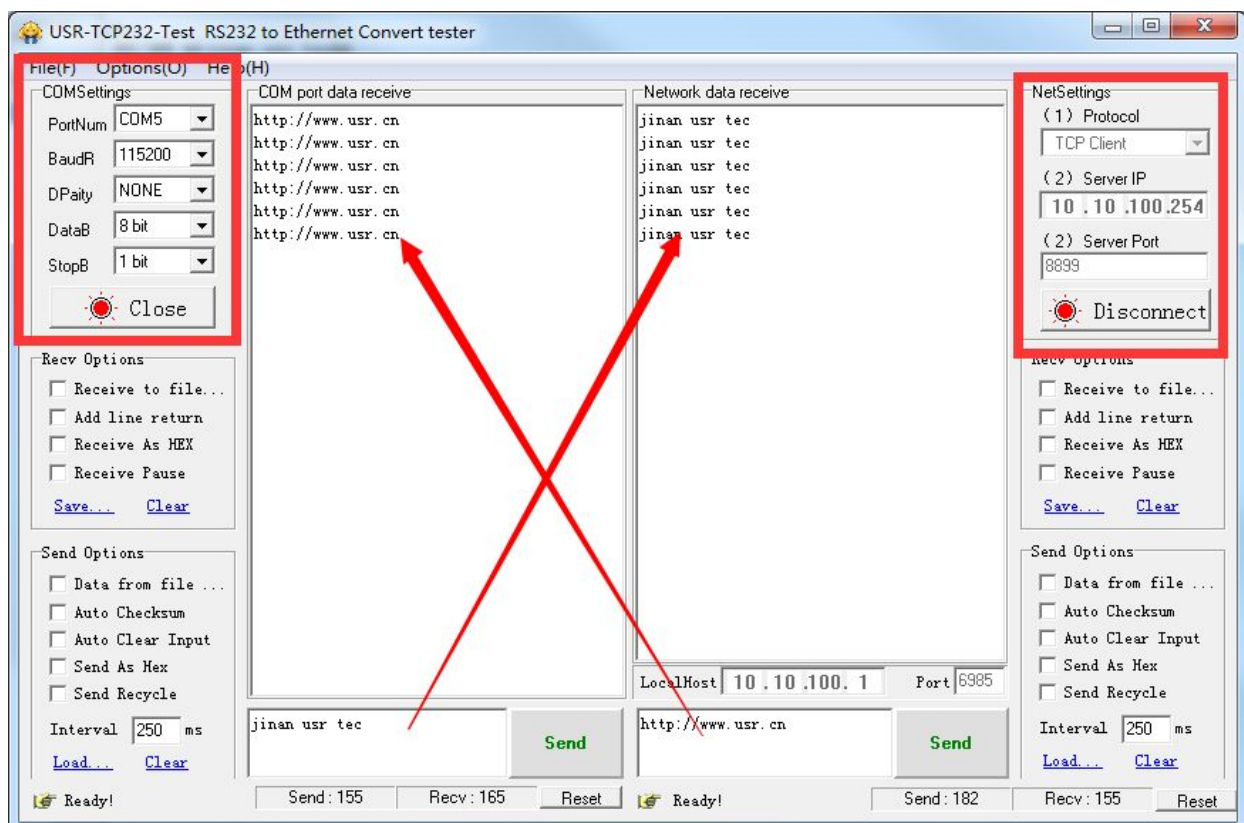

2. Overview

2.1. Brief Introduction

The USR-C215 is integrated with MAC, baseband IC, RF transceiver unit and power amplifier. With built-in low power operation mechanism, can effectively achieve low power running. Support WiFi protocol and TCP/IP protocol, with simple settings, realize connection for serial devices with network. Both on-board antenna and external antenna available, user can select according to your applications.

Dimensions of module: 22*13.5*6mm, single row 1*10 2m encapsulation

Basic functions of module:

- Can work as AP mode, in this mode, other WiFi terminals can join it for communication. Also can work as STA mode, join wireless router and realize transmission.
- Support UART transparent transmission, switch by AT command

2.2. Features

- Support Wi-Fi@2.4 GHz 802.11b/g/n wireless standard
- Support WEP, WPA/WPA2 security
- Support AP, STA, AT+STA work mode
- Integrated serial to WiFi transmission function, multiple UART rate for selection
- Support TCP/UDP Client registration mechanism
- Simplelink/Usrlink fast network setting
- Automatic baudrate adaptation which is similar to RFC2217
- 3.3V single power
- Low power mode, support deep sleep

2.3. Parameters

	Parameters	Value
Wireless Parameters	Wireless standard	802.11 b/g/n
	Transmit	17.0 dBm @ 1 DSSS
		15.0 dBm @ 11 CCK
		13.5 dBm @ 54 OFDM
Receive sensitivity	-91.5 dBm @ 1 DSSS	
	-87.5 dBm @ 11 DSSS	
	-80.5 dBm @ 54 OFDM	
Antenna	External: I-PEX connector Internal: on board ceramic antenna	
Hardware Parameters	Interface	UART
	Working voltage	3.0V~3.6V
	Working current	In AP mode: average 70mA@3.3V In STA mode: average 30ma@3.3V

	Working temprature	-30°C - 70°C
	Storage temprature	-55°C - 125°C
	Dimensions	22mm x 13.5mm x 6mm
	External interface	Pins plug
Software Parameters	Network type	AP, STA, AP+STA
	Security	WEP/WPA-PSK/WPA2-PSK
	Encryption	TKIP,AES ,TKIP/AES
	Net protocol	IPv4, TCP/UDP
	User config	AT + command, Webpage

3. Hardware

3.1. Hardware Information

3.1.1. Dimensions

Dimension of module is 22.0*13.5mm, error ± 0.2 mm

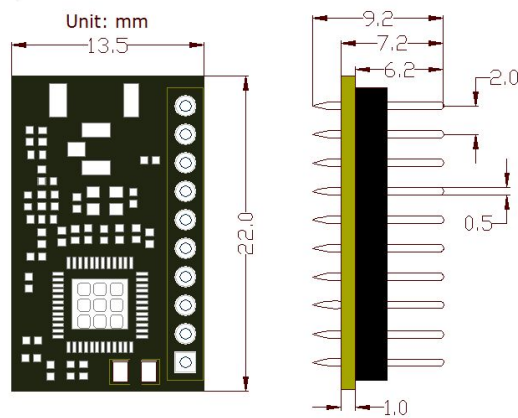

3.1.2. Pin Defination

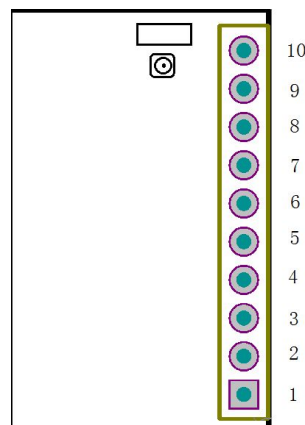

Pin Defination List:

Pin	Name	Type	Description
1	GND	P	GND
2	VDD	P	Positive of power, 3.3V
3	RELOAD	I	Pull down 1-3s: start simplelink Pull down more than 3s: reload to factory defaults
4	RESET	I	Reset, effective in low level
5	UART_RX	I	Receive
6	UART_TX	O	Transmit
7	PWR_SW	N	Vacant, not available
8	WPS	N	Vacant, not available
9	READY	O	Working indicator, effective in low level, can connect external LED
10	nLINK	O	WiFi link indicator, effective in low level, can connect external LED

<Note>

In Type list: power is expressed as P, input is expressed as I, output is expressed as O, not available is expressed as N

3.1.3. Antenna

There are 2 types of antenna: on board chip antenna and external I-PEX connector antenna. Pls select before purchase. To ensure the signal is good, pls pay attention to following points:

- NO component can be put on the antenna parts of PCB
- Antenna should be far away from metal, at least 10mm away, to avoid interfering source like inductance, or strong current.
- Make sure antenna is being open or edge position even for plastic shell.
- Make sure antenna is in the edge of PCB, copper pour is forbidden in the bottom of RF(hollow process is ok)
- Can't be covered by metal shell. Plastic shell should be more than 10mm away from the antenna.

3.1.4. Evaluation kit

We supply evaluation kit for users convenient development. As shown in below image, user can choose UART interface for communication

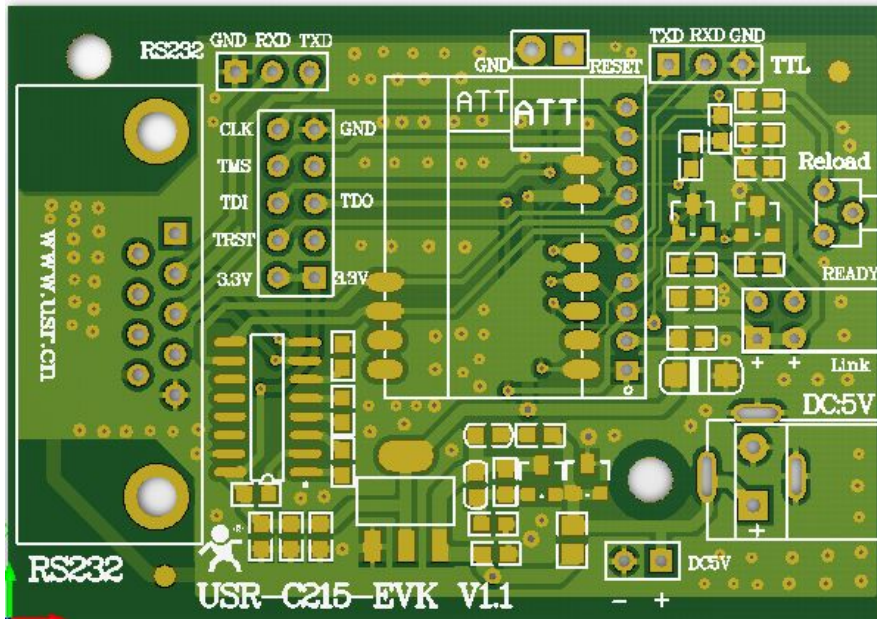

Evaluation kit interface description

Function	Name	Description
External interface	DC Jack	5V power input jacker
	DB9	9-Pin male connector
LED	Ready	Green light, module working indicator
	nLink	Red, nLink/GPIO indicator
Button	nReload	Reload to factory defaults

3.2. Hardware Reference Design

3.2.1. Typical Application Connection

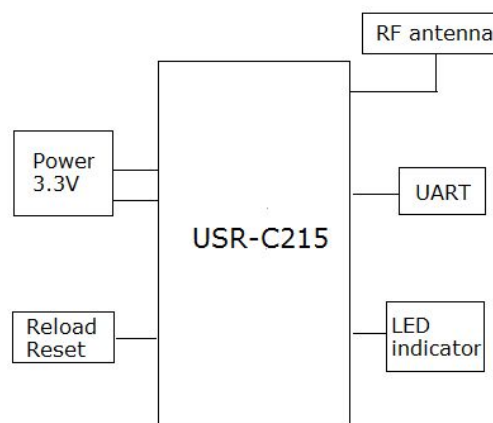

3.2.2. Power Interface

Switching power supply is recommended. VCC working voltage range from 3.0V~3.6V, 3.3V is the best. Power module by main power pin, the pin be in parallel with storage capacitance and high frequency

capacitance. Circuit diagram as shown below:

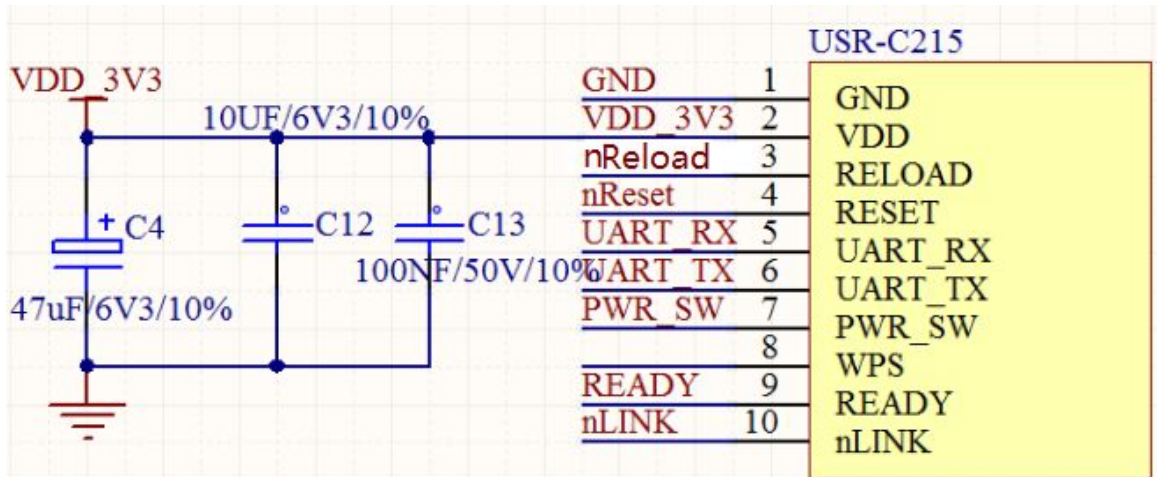

Power Supply Characteristics

Symbol	Parameter	Min	Type	Max	Unit
V_MAIN	Power supply voltage	3.0	3.3	3.6	V

<Note> Io current

AP: 70mA@3.3V

STA: 30mA@3.3V

3.2.3. UART Interface

If communicate with MCU(3.3V) directly, should connect TXD of module to RXD of MCU, connect RXD of module to TXD of MCU. If MCU is 5V level, a switching circuit is needed, see below diagram:

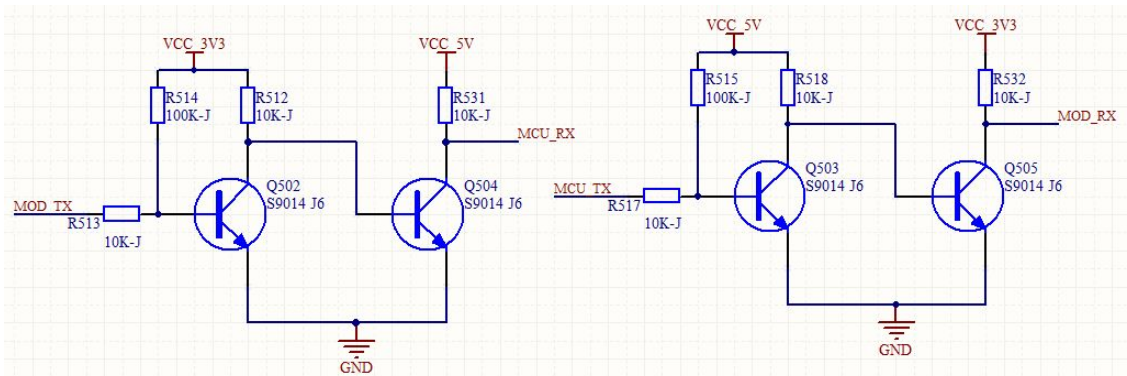

3.2.4. Reset & Reload

USR-C215 support hardware reload function, by connect nReload pin with external button or setting pin. When pull down to "0" for 1~3s, simplelink function will start. When pull down to "0" for more than 3s, module will restore to factory defaults. Here should link to a pull-up resistor (4.7K~10K)

nReset: reset signal, module will restart when it is pulled down. There exist a 100K resistance pull up to 3.3V. When module is powered on or break down, MCU will reset the module, pull down pin at least 0.5s, then pull up or vacant.

Reference diagram as follows:

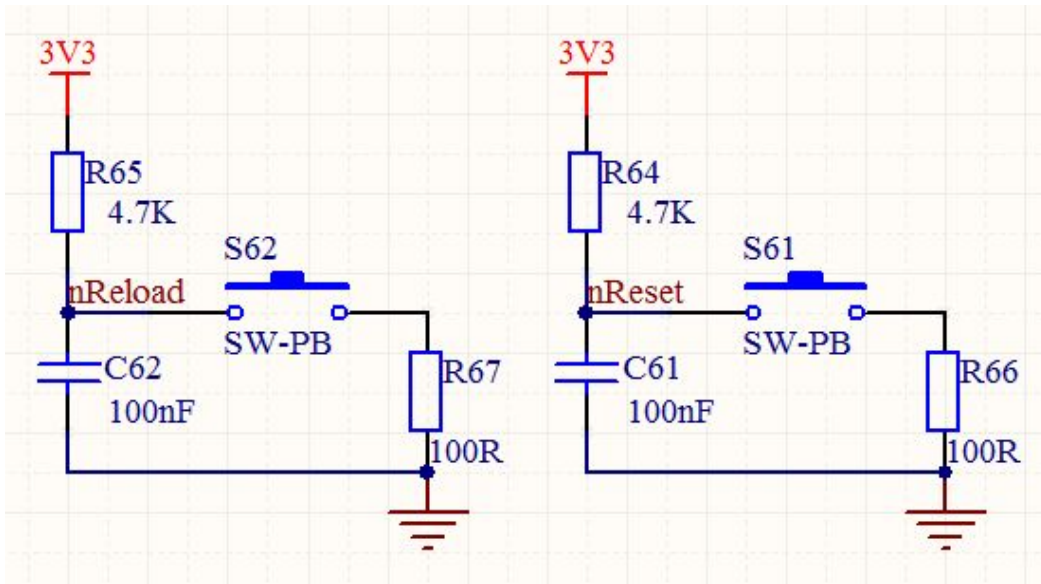

4. Module Function

4.1. Wireless Network Mode

There are 3 types wireless network mode: AP, STA, AP+STA

<Description>

- AP: Access Point, it is the center of wireless network. For example router, router is an AP, other stations can connect to each other through it.
- STA: Station, it is the terminal of wireless network. For example laptop, PAD, cell phone.

4.1.1. Work as STA

It is the most commonly used network type for module to work as STA. Consist of a AP(router) and multi STAs, see below image. The AP is in central position, communication between STAs forward by AP.

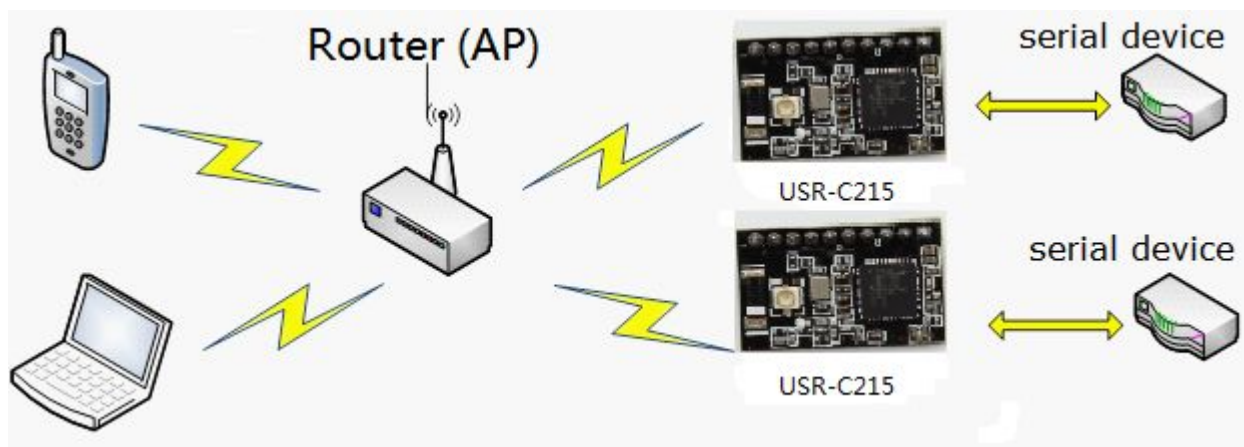

4.1.2. Work as AP

Module can work as AP, in AP mode, cell phone/PAD/PC can get access to module for data transmission without any settings. Besides, user can log in module built-in webpage for configuration.

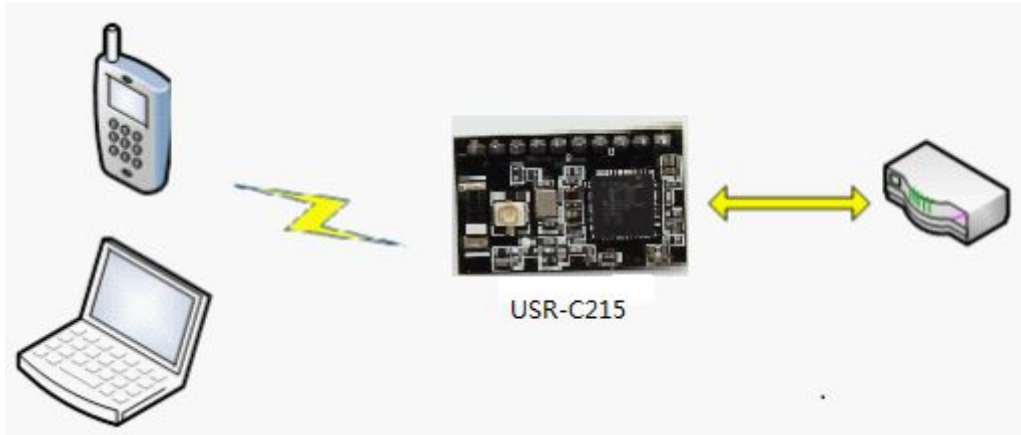

<Note>

When module works in AP mode, 3 STAs can join it.

4.1.3. Work as AP+STA

Module can work as AT and STA at the same time, shown as below:

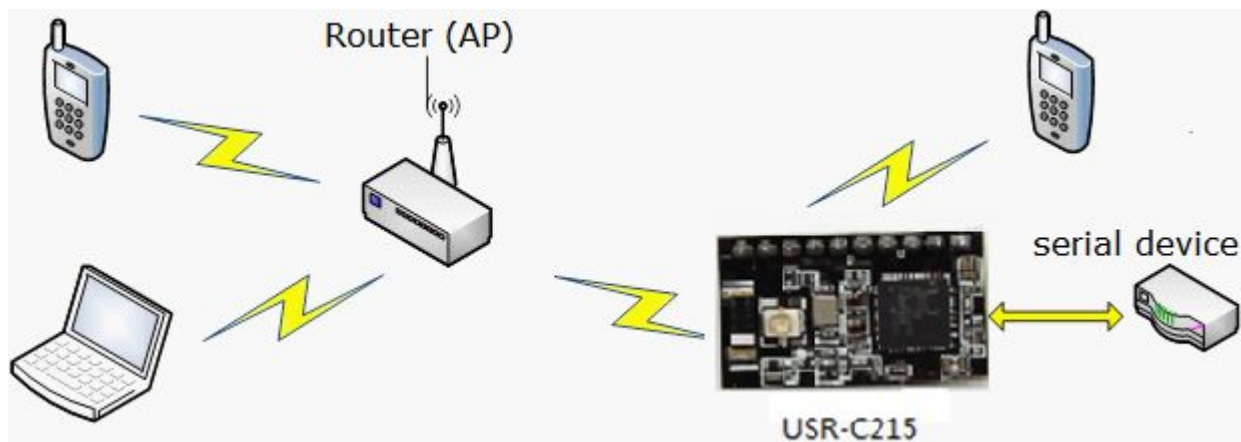

<Note>

In this mode, 3 STAs can join the module network

4.1.4. Encryption Type

To ensure the safety of data communication, module supports variety of encryption type. Including:

- WEP
- WPA-PSK/TKIP
- WPA-PSK/AES
- WPA2-PSK/TKIP
- WPA2-PSK/AES

- Work Mode

4.2. Work Mode

USR-C215 support 2 work mode: transparent transmission mode and command mode

- Transparent transmission mode

In this mode, module will transmit data between UART&WiFi, to realize the communication between serial device and network device.

- Command mode:

In this mode, user can query/set the UART and network parameters by AT commands. Use command AT+ENTM to quit command and switch to transparent transmission mode.

4.2.1. Transparent Transmission Mode

4.2.1.1. Short Description

The advantage of this mode is to realize plug and play between UART interface and network communication, that will reduce the complexity for users. With essential parameter settings in advance, after power on, module will automatically connect to the pre-set wireless network and server.

This mode is fully compatible with users software, which reduce the workload for development of intergrade wireless software.

Parameters need to set in advance

- WiFi network
 - SSID
 - Encryption
 - Password
- Default TCP/UDP connection
 - Protocol
 - Type (Client/Server)
 - Destination Port
 - Destination IP
- UART Interface
 - Baud rate
 - Data bit
 - Stop bit
 - Check bit
 - Hardware flow control (rts/cts)

4.2.1.2. UART Frame

When module receive data sent from UART, it will keep checking the time interval of 2 adjacent bytes. If time interval is greater than frame time you set (default 20ms, can set by command AT+UARTTE), module will

judge this frame is over, or it will keep receiving data. In command mode, if greater than 1K bytes, module will discard the received data. In transparent transmission mode, if greater than 1K bytes, module will send in packet.

Packet process as following diagram: n is packet time interval, unit: ms

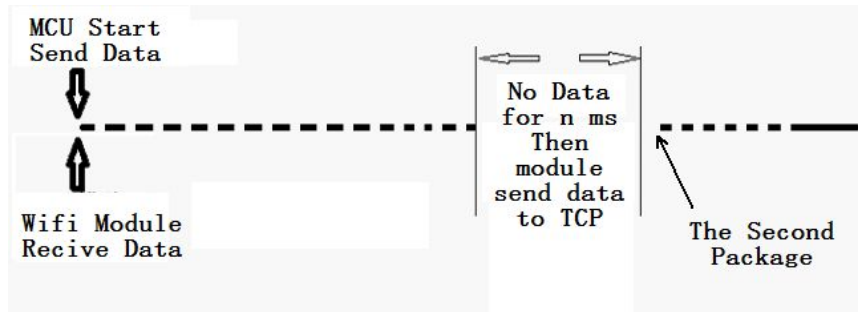

4.2.2. Command Mode

In command mode, module no longer work for transparent transmission, UART interface is used to receive AT command. User can send AT command to module by UART, to query/set parameters of UART and network.

Detailed AT instruction pls refer to chapter 5.3

4.3. Socket Connection

Module has a serial port UART0, which can communicate with Socket connection.

There are 2 Sockets: Socketa and Socketb

When module works in transparent transmission mode, the data sent to UART, will automatically be sent to Socket. The data received by Socket, will be sent out by UART interface.

Protocol for Socketa: TCP Server, TCP Client, UDP Server, UDP Client. Setting method refer to command AT+NETP

Protocol for Socketb: TCP Client, UDP Server, UDP Client. Setting method refer to command AT+SOCKB

When it set to be TCP Server, can support up to 5 TCP Clients for 5 Socket connections. In multi TCP connection, data from TCP transmission will be forwarded one by one to UART interface. Data from UART will be copied into multi and be forwarded to each TCP connection. Data flow diagram as follows:

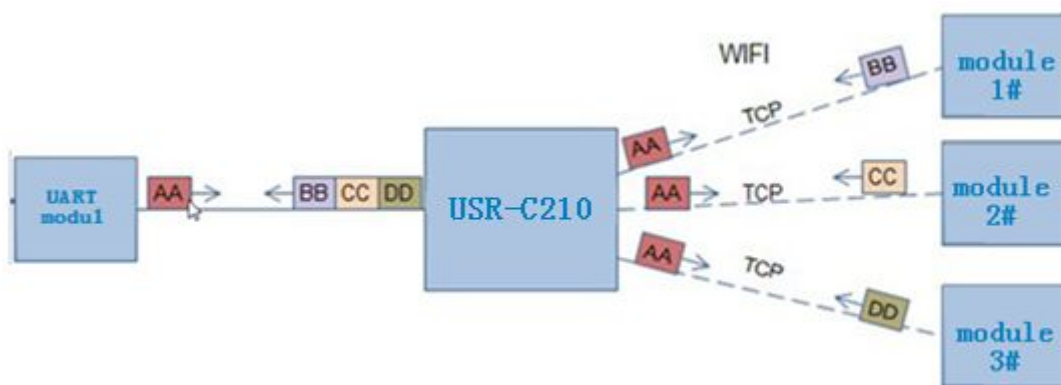

When it set to be UDP Server, if UART receive data first, module will send data to pre-set IP and Port (set by AT+NETP or AT+SOCKB). If UDP Server receive data, module will remember the source address which sent

data, afterwards when UART receive data, module will forward data to this address.

When it set to be UDP Client, module send to the pre-set IP and Port only, and only receive data from pre-set IP and Port. Data from other address will not be sent to UART.

4.4. Search in LAN

Module can be searched in LAN, that is, when module get access to the wireless router, user can obtain module current IP address by sending UDP broadcast to a certain port, to realize device search and communicate. The port and keywords can be set by AT+SEARCH, default 48899,www.usr.cn

Search Tool Process

1. On another device in LAN, send a command by UDP broadcast

UDP broadcast: address xx.xx.xx.255, port 48899

Command: www.usr.cn, max 20 bytes can be set

2. After module receiving the command, if command is correct, module will switch to config mode, send local IP, MAC, MID and version no. to this address

(IP, MAC, MID, ver example: 10.10.100.254, D8B04CFC0000, USR-C215, 01.01.10)

Module will quit the config mode, if it did not receive setup commands in 30s after get into config mode. User need to resend search commands to switch config mode.

3. User can query/set module work status by sending network AT command to this port. AT command the same as UART AT command.

<Note>

Search tool must be in the same LAN with module. If multi STAs connect to a router, the PC with search tool also under this router, search tool will obtain all STAs modules.

4.5. Registration Packet Mechanism

When module works in TCP Client or UDP Client mode, user can open registration packet function, in this way, server can distinguish data source, to realize data monitoring for different devices. There are 2 type: MAC and ID. MAC is 6 bytes, ID range from 1~65535. We no longer use ID, but recommend MAC now.

Command AT+REGENA to open and close this function.

Registration packet mechanism way as follows:

- TCP Client: 2 ways
 - Send once only. When module connect to TCP Server, module will send registration packet to TCP Server.
 - Send in each data packet. When TCP Client connect to server, registration packet will be insert into the front of each data packet
- UDP Client
 - Registration packet will be insert into the front of each data head and send.

4.6. Usrlink (Fast Networking Protocol)

When module works in AP mode, will open an UDP port, which is used to receive fast networking protocol command, port number is 48899 (the same as search in LAN port, can be set). Smart phone can connect with module WiFi network directly, through commands under UDP protocol, query SSID information list and set

router SSID&Password. After setup, module will restart and connect to pre-set router. Now module works in STA mode.

Protocol format instructions

- Query command

No.	Name	No. of bytes	Instruction
1	Packet head	1	Fixed value 0xFF
2	Length	2	All the bytes after length (not included) and in front of check (not included)
3	Command word	1	Command type, 0x01 is query command
4	Check words	1	Cumulate SUM of all bytes after packet head (not included) and in front of check (not included)

- Query response command

No.	Name	No. of bytes	Instruction
1	Packet head	1	Fixed value 0xFF
2	Length	2	All the bytes after length(not included) and in front of check(not included)
3	Command word	1	Command type, corresponding response command for query command is 0x81
4	No. of AP	1	No. of AP that searched at present
5	SSID1	Not regular	SSID of router 1
6	End mark	1	SSID end mark of router 1, fixed value 0x00
7	Signal strength 1	1	Signal strength of router 1 network, range from 0~100, corresponding actual value is 0%~100%
8	End mark	2	End mark of signal strength 1, 0x0D, 0x0A.
...
M	SSIDn	Not regular	SSID of router n
M+1	End mark	1	SSID end mark of router n, fixed value 0x00
M+2	Signal strength n	1	Signal strength of router n network, range from 0~100, corresponding actual value is 0%~100%
M+3	End mark	2	End mark of signal strength n, 0x0D, 0x0A.
M+4	Check words	1	Cumulate SUM of all bytes after packet head (not included) and in front of check (not included)

Example:

Smart phone send to module (in HEX): FF 00 01 01 02

Module response to smart phone (in HEX): FF 00 14 81 02 54 45 53 54 31 00 40 0D 0A
 54 45 53 54 32 00 37 0D 0A 1F

Explanation: smart phone send query command to module to check router information. Module replied information to smart phone: there are 2 routers. SSID of router 1 is "TEST1", signal strength is 64%. SSID of router 2 is "TEST2", signal strength is 55%

<Note>

The router information that module replied is ordered according to signal strength.

- Set instructions

No.	Name	No. of bytes	Instruction
1	Packet head	1	Fixed value 0xFF
2	Length	2	All the bytes after length (not included) and in front of check (not included)
3	Command word	1	Command type, 0x02 is query command
4	Reserved word	1	Default 0x00
5	SSID	Not regular	SSID of router
6	Separator	2	Separator of SSID, fixed value 0x0D, 0x0A
7	Password	Not regular	Password of router
8	Check words	1	Cumulate SUM of all bytes after packet hear (not included) and in front of check (not included)

- Response instructions

No.	Name	No. Of bytes	Instruction
1	Packet head	1	Fixed value 0xFF
2	Length	2	All the bytes after length (not included) and in front of check (not included)
3	Command word	1	Command type, 0x82 is the corresponding response command for setting command
4	Check value	1	Check result for SSID 0x01: corresponding network for SSID can be find 0x00: can't be find
5	Check value	1	Check result for password 0x01: password correct 0x00: password incorrect
6	Check words	1	Cumulate SUM of all bytes after packet hear (not included) and in front of check (not included)

Example

Mobile phone send to module (in HEX): FF 00 0F 02 00 54 45 53 54 31 0D 0A 31 32 33 34 35 36 CE

Module response to mobile phone (in HEX): FF 00 03 82 01 01 87

Instruction: mobile phone send setting command to module, set SSID to be "TEST1", password to be "123456". The information which module reply to phone is: the network "TEST1" is exist, password is correct

4.7. Simplelink

This function is to realize module for intelligent networking, that is to connect to AP easily, no need to establish connection with module. Steps:

1. Install the APP in mobile

2. Pull down Reload pin for 1-3s, module will switch to Simplelink mode. Ready pin output 0.5Hz level.
3. Open APP in mobile, input password, click "connect"
4. Module will restart if connect to AP successfully. APP will receive MAC address sent by module.

4.8. Class RFC2217

RFC2217 is a standard protocol which is used to modify UART settings by Ethernet port. USR-C215 support a protocol that is class with RFC2217, can realize the same function, but it is easier.

After sending command to device, will excute UART settings and reply nothing if ok. If check or protocol incorrect, it will be regarded as common data packet and forwarded by serial port.

It is workable in TCP Client, TCP Server, UDP Client, UDP Server mode.

Its modification will immediatly take effect, no need to restart, valid for once, not saved, lost if power off.

Protocol length: 8 bytes. Example in HEX, detailed protocol as follows:

Name	Packet header	Baud rate	Bit	Sumcheck
No. Of bytes	3	3	1	1
Instruction	3 bytes to reduse error	3 bytes mean one baud rate value, high in front	Different bit means different, see attached list	Sumcheck of 4 bit in front, ignore carry
Example (115200,N,8,1)	55 AA 55	01 C2 00	83	46
Example (9600,N,8,1)	55 AA 55	00 25 80	83	28

Attached: Bit instructions

Bit No.	Instruction	Value	Description
1:0	Data bit choose	00	5
		01	6
		10	7
		11	8
2	Stop bit	0	1
		1	2
3	Check bit enable	0	Disable
		1	Enable
5:4	Check bit type	00	ODD
		01	EVEN
		10	Mark
		11	Clear
7:6	Undefinition	00	Pls write 0

5. Setting Method

Module can be set by Webpage and AT command

5.1. Webpage

First time when use the module, we should do some necessary settings.

Access into Webpage:

1. Open WiFi network and search
2. Scan WiFi and select USR-C215, connect
3. Input 10.10.100.254 in browser
4. Input username and password

Default settings:

Parameters	Default settings
SSID	USR-C215
IP address	10.10.100.254
Username	admin
Password	admin

Access into the webpage, you can choose English on the top right conner. There are 6 parts in total: "Sys Status", "Trans Setting", "Extra function", "System Setting", "About USR"

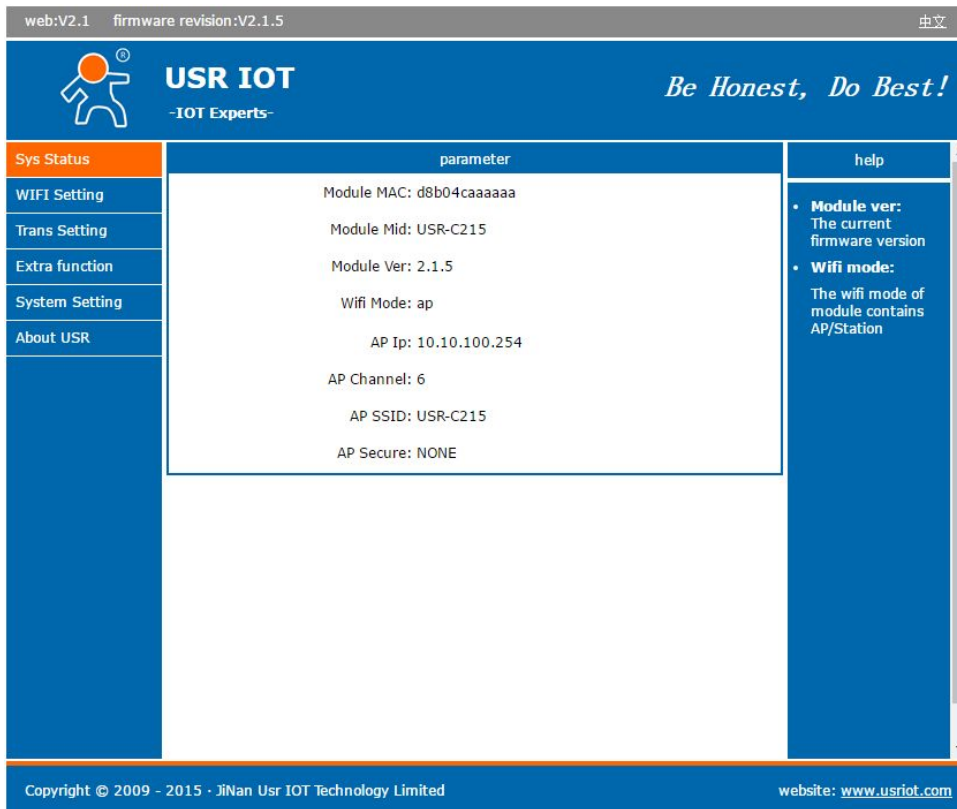

The screenshot shows the USR IOT web interface. At the top, it displays 'web:V2.1 firmware revision:V2.1.5' and a language selector '中文'. The main header features the USR IOT logo and the slogan 'Be Honest, Do Best!'. A navigation menu on the left includes 'Sys Status', 'WIFI Setting', 'Trans Setting', 'Extra function', 'System Setting', and 'About USR'. The 'Sys Status' page shows a table of parameters:

parameter	help
Module MAC: d8b04caaaaaa	<ul style="list-style-type: none"> • Module ver: The current firmware version • Wifi mode: The wifi mode of module contains AP/Station
Module Mid: USR-C215	
Module Ver: 2.1.5	
Wifi Mode: ap	
AP Ip: 10.10.100.254	
AP Channel: 6	
AP SSID: USR-C215	
AP Secure: NONE	

At the bottom, the footer contains 'Copyright © 2009 - 2015 · JiNan Usr IOT Technology Limited' and 'website: www.usriot.com'.

5.1.1. WiFi Parameter Setting

Here we can set WiFi work mode: AP, STA, AP+STA

Set parameters in AP or STA mode, click "Save" to save your settings.

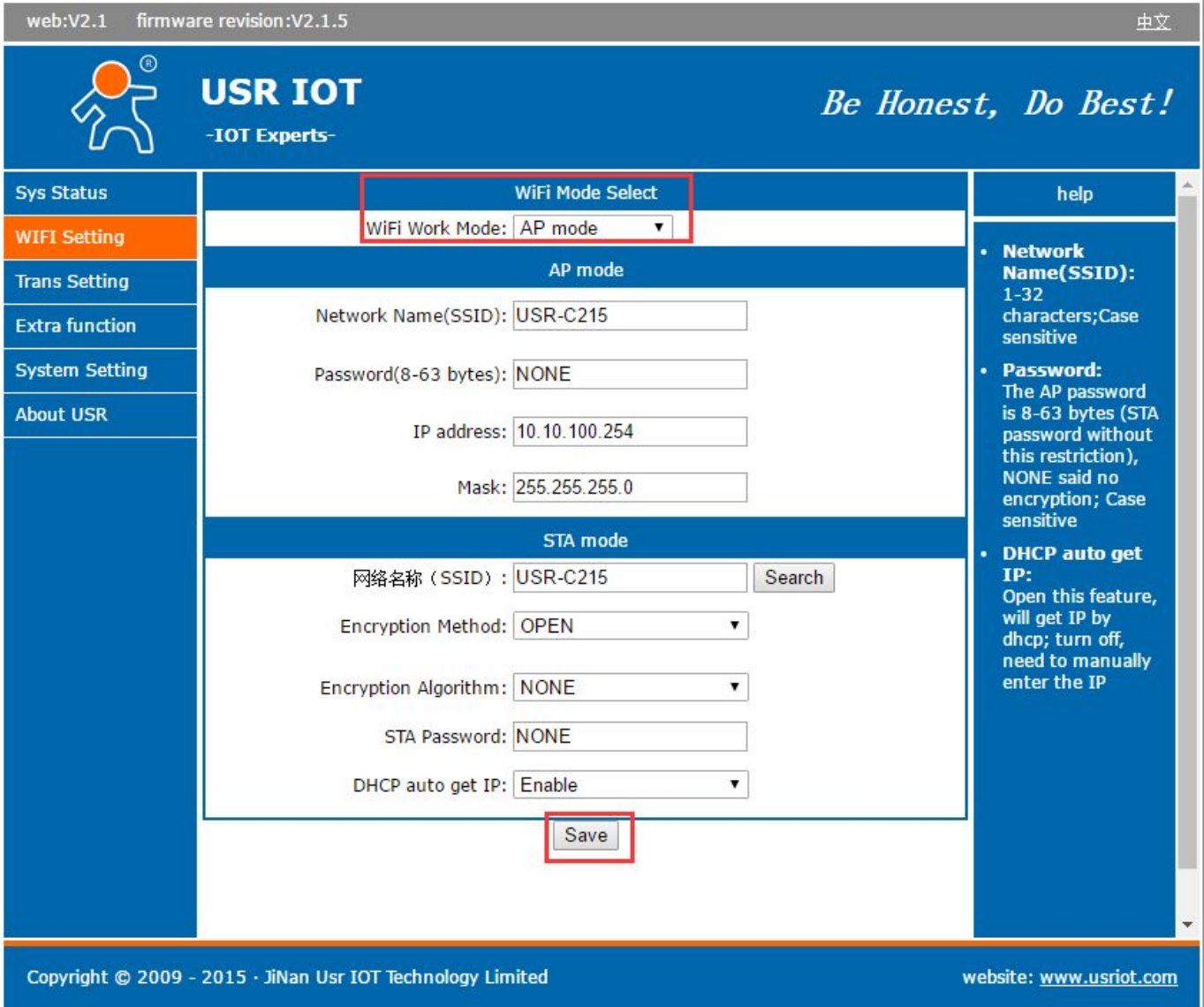

web:V2.1 firmware revision:V2.1.5 中文

USR IOT
-IOT Experts- *Be Honest, Do Best!*

Sys Status **WiFi Mode Select** help

WIFI Setting WiFi Work Mode: AP mode

Trans Setting **AP mode**

Extra function Network Name(SSID): USR-C215

System Setting Password(8-63 bytes): NONE

About USR IP address: 10.10.100.254

Mask: 255.255.255.0

STA mode

网络名称 (SSID): USR-C215 Search

Encryption Method: OPEN

Encryption Algorithm: NONE

STA Password: NONE

DHCP auto get IP: Enable

Save

- **Network Name(SSID):** 1-32 characters;Case sensitive
- **Password:** The AP password is 8-63 bytes (STA password without this restriction), NONE said no encryption; Case sensitive
- **DHCP auto get IP:** Open this feature, will get IP by dhcp; turn off, need to manually enter the IP

Copyright © 2009 - 2015 · JiNan Usr IOT Technology Limited website: www.usriot.com

5.1.2. Transparent Transmission Parameter Setting

1. Serial Port Settings, including: baud rate, data, check, stop, CTS/RTS
2. Socket Connection Settings, including: protocol, IP, Port
3. Socketb Connection Settings, including: protocol, IP, Port.

Click "Save" to save your settings.

web:V2.1 firmware revision:V2.1.5
中文



USR IOT
 -IOT Experts-

Be Honest, Do Best!

<ul style="list-style-type: none"> Sys Status WIFI Setting <li style="background-color: #0056b3; color: white;">Trans Setting Extra function System Setting About USR 	<div style="border: 1px solid #0056b3; padding: 5px; margin-bottom: 5px;"> <p style="text-align: center; margin: 0;">Serial Port Set</p> <p>Baud rate (1200-460800 bps): <input type="text" value="115200"/> bps</p> <p>Data Num: <input type="text" value="8"/> bit</p> <p>Check bit: <input type="text" value="None"/></p> <p>Stop bit: <input type="text" value="1"/> bit</p> <p>CTSRTS/485: <input type="text" value="NFC"/></p> </div> <div style="border: 1px solid #0056b3; padding: 5px; margin-bottom: 5px;"> <p style="text-align: center; margin: 0;">Socket Connect Set</p> <p>protocol: <input type="text" value="TCP-Server"/></p> <p>port: <input type="text" value="8899"/></p> <p>Server IP Address: <input type="text" value="10.10.100.254"/></p> </div> <div style="border: 1px solid #0056b3; padding: 5px; margin-bottom: 5px;"> <p style="text-align: center; margin: 0;">Socketb Connect Set</p> <p>protocol: <input type="text" value="OFF"/></p> <p>port: <input type="text" value="8899"/></p> <p>Server IP Address: <input type="text" value="10.10.100.254"/></p> </div> <p style="text-align: center; margin: 0;"><input type="button" value="Save"/></p>	<p style="text-align: center; margin: 0;">help</p> <ul style="list-style-type: none"> • Baud rate: 1200-460800bps • CTSRTS/485: Default is NFC • port: 1~65535 • Server IP Address: When the module is Client, the remote server address to be connected; When it's TCP server, the parameter is invalid; The parameter can be IP or domain name
---	--	--

Copyright © 2009 - 2015 · JiNan Usr IOT Technology Limited
website: www.usriot.com

5.1.3. Extra Function

RFC2217: Disable/Enable

Search in LAN: default port 48899, command www.usr.cn

Registration Mechanism

Module MID: default USR-C215, max 20 bytes

web:V2.1 firmware revision:V2.1.5
中文



USR IOT
 -IOT Experts-

Be Honest, Do Best!

Sys Status	RFC2117 function	help
WIFI Setting	RFC2117: <input type="text" value="Disable"/>	<ul style="list-style-type: none"> RFC2117: Automatic Baud Rate Function; Please cooperate with "USR-VCOM.exe" to use search name: Up to 20 bytes Register mechanism Registration Packet Mechanism; Used to send the ID/MAC to the server; Work only in TCP client regist ID 1~65535
Trans Setting	search in network	
Extra function	search port: <input type="text" value="48899"/>	
System Setting	search name: <input type="text" value="www.usr.cn"/>	
About USR	Regist mechanism	
	regist content: <input type="text" value="OFF"/>	
	regist frequency(just for TCPC): <input type="text" value="FIRST"/>	
	regist ID (0-65535): <input type="text" value="0"/>	
	USER register(within 32Byte): <input type="text" value="USR-C215"/>	
	CLOUD ID(20 figure): <input type="text" value="00000000000000000000"/>	
	CLOUD Password(within 8Byte): <input type="text" value="password"/>	
	module MID	
	MID: <input type="text" value="USR-C215"/>	
	<input type="button" value="Save"/>	

Copyright © 2009 - 2015 · JiNan Usr IOT Technology Limited
website: www.usriot.com

5.1.4. System Setting

Reload&Restart

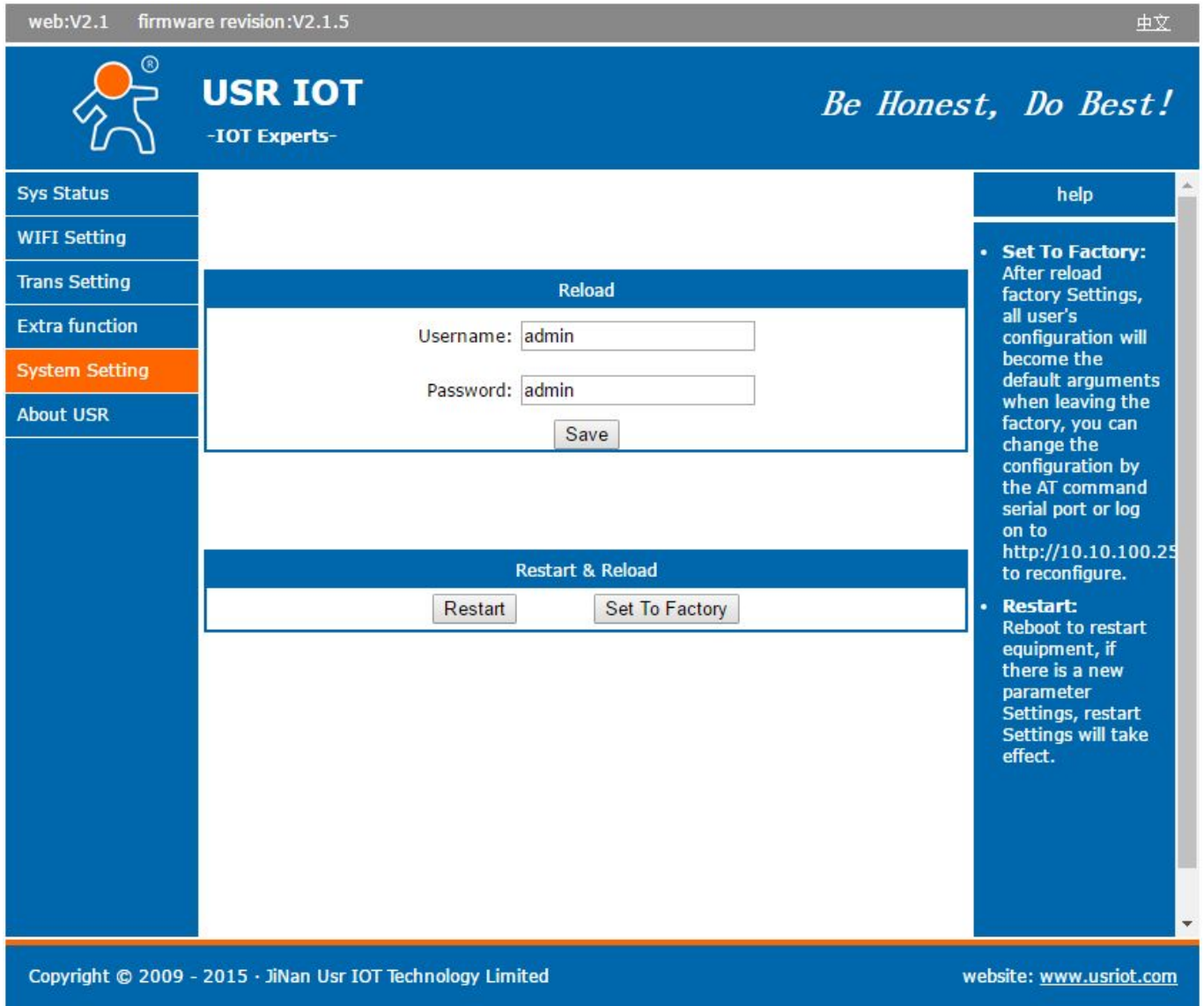

The screenshot displays the USR IOT web interface for system settings. At the top, it shows 'web:V2.1' and 'firmware revision:V2.1.5' on the left, and a '中文' (Chinese) language selector on the right. The main header features the USR IOT logo and the slogan 'Be Honest, Do Best!'. A left sidebar contains navigation links: 'Sys Status', 'WIFI Setting', 'Trans Setting', 'Extra function', 'System Setting' (highlighted in orange), and 'About USR'. The main content area is titled 'Reload' and contains a form with 'Username: admin' and 'Password: admin' fields, and a 'Save' button. Below this is a 'Restart & Reload' section with 'Restart' and 'Set To Factory' buttons. A right sidebar, titled 'help', contains two bullet points: 'Set To Factory: After reload factory Settings, all user's configuration will become the default arguments when leaving the factory, you can change the configuration by the AT command serial port or log on to http://10.10.100.25 to reconfigure.' and 'Restart: Reboot to restart equipment, if there is a new parameter Settings, restart Settings will take effect.' The footer includes 'Copyright © 2009 - 2015 · JiNan Usr IOT Technology Limited' and 'website: www.usriot.com'.

5.1.5. About USR

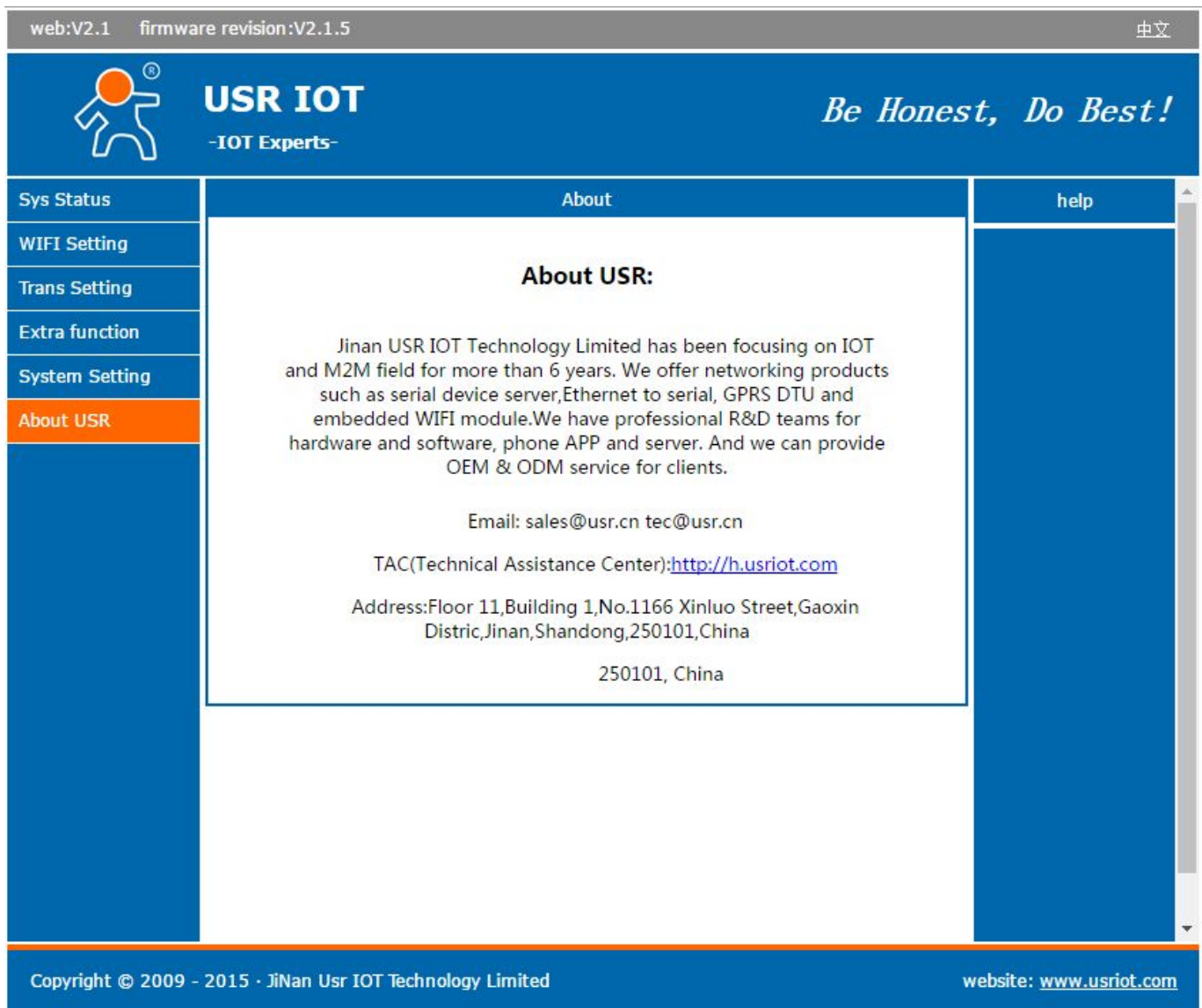

The screenshot shows a web browser interface for the USR IOT device. At the top, it displays 'web:V2.1' and 'firmware revision:V2.1.5' on the left, and a '中文' (Chinese) language selector on the right. The main header features the USR IOT logo, the text 'USR IOT -IOT Experts-', and the slogan 'Be Honest, Do Best!'. A left sidebar contains a menu with items: 'Sys Status', 'WIFI Setting', 'Trans Setting', 'Extra function', 'System Setting', and 'About USR' (which is highlighted in orange). The main content area is titled 'About' and contains the following text:

About USR:

Jinan USR IOT Technology Limited has been focusing on IOT and M2M field for more than 6 years. We offer networking products such as serial device server, Ethernet to serial, GPRS DTU and embedded WIFI module. We have professional R&D teams for hardware and software, phone APP and server. And we can provide OEM & ODM service for clients.

Email: sales@usr.cn tec@usr.cn

TAC(Technical Assistance Center):<http://h.usriot.com>

Address: Floor 11, Building 1, No.1166 Xinluo Street, Gaoxin Distric, Jinan, Shandong, 250101, China

250101, China

At the bottom of the page, there is a footer with 'Copyright © 2009 - 2015 · JiNan Usr IOT Technology Limited' on the left and 'website: www.usriot.com' on the right.

5.2. AT Command Instructions

In AT command mode, module can be set by UART.

Default UART settings: 115200, None, 8, 1

<Note>

We recommend SecureCRT as AT command debug tool

Steps to switch transparent transmission mode to AT command mode:

1. Input “+++” in UART
2. Module receive and reply “a”
3. Input “a” in UART
4. Module receive and reply “+OK”, switch into AT command mode

<Note 1>

There is no echo when input “+++” and “a”, as below image

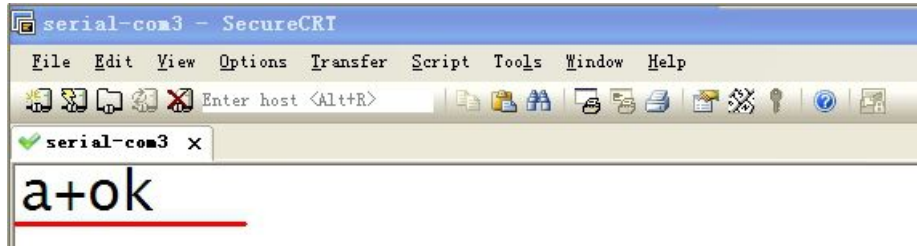

<Note 2>

To avoid the module get into command mode in normal work, need to input “+++” and “a” within a certain time, see requirement below:

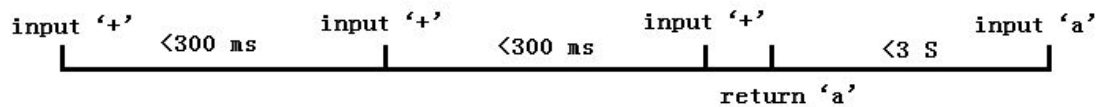

Steps to switch to AT command mode to transparent transmission mode

1. In AT command mode, input AT+ENTM, end with carriage return

5.2.1. AT Command Description

AT+ command can be input through serial debugger and programs

AT+ command adopts the command line based on ASCII code, command format as follows:

- Format Instruction
 - < >: essential part
 - []: optional part
- Command Information
 - AT+<CMD>[op][para-1,para-2,para-3,para-4,...]<CR>**

AT+: prefix of command

[op]: command operator, indicate Query or Set

- “=”: set
- “NULL”: Query

[para-n]: the input parameter for settings, no need for query

<CR>: end mark, carriage return, 0X0A or 0X0D in ASCII

<Note>

If user did not close echo function(AT+E), the command which you input will be send back, <CR> not back.

- Response Information
 - <CR><LF>+<RSP>[op] [para-1,para-2,para-3,para-4,...]<CR><LF>**

+: prefix of reponse information

RSP: response character string,including

- “OK”: succeed
- “ERR”: failed

[para-n]: response parameters or error code

<CR>: 0x0d in ASCII code

<LF>: 0x0a in ASCII code

➤ Error code

Error code list

Error code	Instructions
-1	Invalid command format
-2	Invalid command
-3	Invalid operator
-4	Invalid parameter
-5	Operating not permit

5.3. AT Instruction Set

5.3.1. AT Command List

NO	Command	Description
Manage command		
1	E	Open/Close echo function
2	WMODE	Query/Set Wi-Fi mode (AP/STA/APSTA)
3	ENTM	Enter transparent transmission mode
4	MID	Query module ID
5	RELD	Reload to factory defaults
6	Z	Reset module
7	H	Help (not available now)
Config parameters command		
8	CFGTF	Copy user settings to factory defaults
UART command		
9	UART	Query/Set UART settings
10	UARTTE	Query/Set time interval between each 2 bytes for free frame
SOCK A parameters command		
11	NETP	Query/Set network protocol parameters
12	TCPLK	Query whether TCP link established
13	TCPDIS	Connect/Disconnect TCP link
SOCK B parameters command		
14	SOCKB	Query/Set network protocol parameters of SOCKB
15	TCPDISB	Connect/Disconnect TCP_B link
16	TCPLKB	Query whether TCP_B link established
WiFi STA command		
17	WSSSID	Query/Set SSID that related to AP
18	WSKEY	Query/Set encrypting parameters of STA
19	WANN	Query/Set network parameters of STA

20	WSMAC	Query MAC address of STA
21	WSLK	Query wireless link status of STA
22	WSLQ	Query signal strength for STA to connect AP
23	WSCAN	Scan AP
24	WSDNS	Query/Set DNS server address in STA mode for static setting
WiFi AP command		
25	LANN	Query/Set network parameters of AP
26	WAP	Query/Set WiFi config parameter of AP
27	WAKEY	Query/Set encrypting parameters of AP
28	WALK	Query MAC address of STA which connect to AP
Webpage command		
29	PLANG	Query/Set language of webpage
D2D command (not recommend)		
30	DTDDIS	Open/Close D2D function
31	DTDID	Query/Set D2D ID
Other command		
32	WRMID	Set module ID
33	ASWD	Query/Set search command of module
34	SMTLK	Open Smartlink function
35	USERVER	Query user version and compile time
36	RPTMAC	Query whether open report MAC function
37	WRRPTMAC	Set whether open report MAC function

5.3.1.1. AT+E

- Function: Query/Set echo settings of at command
- Format:
 - ◆ Query
AT+E <CR>
+OK=<on/off><CR><LF><CR><LF>
 - ◆ Set
AT+E=<on/off><CR>
+OK<CR><LF><CR><LF>
- Parameters:
 - on: open echo, echo the command that in AT command mode.
 - Off: do not echo the command in AT command mode.

5.3.1.2. AT+WMODE

- Function: Query/Set WiFi work mode (AP/STA/APSTA)
- Format:

- ◆ Query
AT+WMODE<CR>
+ok=<mode><CR><LF><CR><LF>
- ◆ Set
AT+ WMODE=<mode><CR>
+ok<CR><LF><CR><LF>
- Parameters:
 - ◆ Mode: WI-FI work mode
AP
STA
APSTA

5.3.1.3. AT+ENTM

- Function: switch to transparent transmission mode
- Format:
AT+ENTM<CR>
+ok<CR><LF><CR><LF>

After the command execute correctly, module will switch to transparent transmission mode

5.3.1.4. AT+MID

- Function: Query module ID
- Format:
AT+MID<CR>
+ok=<module_id><CR><LF><CR><LF>
- Parameters:
module_id: module ID
USR-C215

Note: can set this parameter by AT+WRMID

5.3.1.5. AT+RELD

- Function: Reload to factory defaults
- Format
AT+ RELD<CR>
+ok=rebooting...<CR><LF><CR><LF>

This command restore factory defaults, then restart automatically

5.3.1.6. AT+Z

- Function: Reset
- Format:

AT+ Z<CR>

5.3.1.7. AT+H (not available now)

- Function: Help
- Format:
 - AT+H<CR>
 - +ok=<command help><CR><LF><CR><LF>
- Parameters:
 - command help: command help instruction

5.3.1.8. AT+CFGTF

- Function: Copy user config parameters to be factory defaults
- Format:
 - Query
 - AT+CFGTF<CR>
 - +ok=<status><CR><LF><CR><LF>
- Parameters:
 - ✧ status: response operate status
 - SAVED: set succeed
 - NON-SAVED: set failed

5.3.1.9. AT+UART

- Function: Query/Set UART settings
- Format:
 - ◆ Query
 - AT+UART<CR>
 - +ok=<baudrate,data_bits,stop_bit,parity,flowctrl><CR><LF><CR><LF>
 - ◆ Set
 - AT+UART=<baudrate,data_bits,stop_bit,parity,flowctrl><CR>
 - +ok<CR><LF><CR><LF>
- Parameters:
 - ✧ baudrate:
 - 1200,2400,4800,9600,14400,19200,38400,57600,115200,128000,
 - 153600,230400 bit/s
 - ✧ data_bits:
 - 8
 - ✧ stop_bits:
 - 1
 - ✧ parity:
 - NONE

- EVEN
- ODD
- MARK
- SPACE
- ✧ flowctrl:
 - hardware flow control CTSRTS
 - NFC: no flow control

5.3.1.10. AT+UARTTE

- Function: Query/Set time interval of free framing
- Format:
 - ◆ Query
AT+ UARTTE<CR>
+OK=<num><CR><LF><CR><LF>
 - ◆ Set
AT+ UARTTE=<num ><CR>
+OK<CR><LF><CR><LF>
- Parameters:

num: range from 20-250, unit in ms. Time interval between 2 bytes in free frame mode.

Note: now parameters will automatically change when setting baudrate. If need modifying time interval, need to set baudrate in advance.

When baudrate <= 1200, num=250ms

When baudrate >= 20000, num=20ms

When 1200 < baudrate < 20000, num=2000/baudrate*10*20, num take integer

5.3.1.11. AT+NETP

- Function: Query/Set network protocol parameter
- Format:
 - ◆ Query
AT+NETP<CR>
+ok=<protocol,CS,port,IP><CR><LF><CR><LF>
 - ◆ Set
AT+NETP=<protocol,CS,port,IP><CR>
+ok<CR><LF><CR><LF>
- Parameters:
 - ✧ protocol:
 - TCP
 - UDP
 - ✧ CS: network mode
 - SERVER
 - CLIENT
 - ✧ Port: protocol port, in decimal, less than 65535

- ✧ IP: when module is set to be “Client”, the destination IP address

If module set to be UDP, SERVER mode, IP address and port can be saved. Module will automatically save the latest received IP address and port, and send data to this address. Module in initialization mode, will send data to this address and port.

If set to be UDP, CLIENT mode, no remeber function.

5.3.1.12. AT+TCPLK

- Function: Query whether TCP link is established
- Format:
 - AT+ TCPLK<CR>
 - +ok=<sta><CR><LF><CR><LF>
- Parameters:
 - ✧ sta.: whether TCP link is established
 - on: established
 - off: not established

5.3.1.13. AT+TCPDIS

- Function: Connect/Disconnect TCP link
- Format:
 - ◆ Query
 - AT+TCPDIS<CR>
 - +ok=<sta><CR><LF><CR><LF>
 - ◆ Set
 - AT+ TCPDIS =<on/off><CR>
 - +ok<CR><LF><CR><LF>
- Parameters:
 - ✧ sta: reply the TCP Client status, if can be connect or not
 - on: can be connect
 - off: can't be connect

5.3.1.14. AT+SOCKB

- Function: Query/Set SOCKB network protocol parameters
- Format:
 - ◆ Query
 - AT+SOCKB<CR>
 - +ok=<protocol,port,IP><CR><LF><CR><LF>
 - ◆ Set
 - AT+SOCKB=<protocol,port,IP><CR>
 - +ok<CR><LF><CR><LF>
- Parameters:

- ✧ protocol:
 - TCP: TCP Client
 - UDP: UDP Client
 - USPS: UDP Server
- ✧ Port: protocol port, in decimal, less than 65535
- ✧ IP: destination IP address, support DNS

If module set to be UDPS, IP address and port can be saved. Module will automatically save the latest received IP address and port, and send data to this address. Module in initialization mode, will send data to this address and port.

Note: SOCKETB can be closed by command AT+SOCB=NONE

5.3.1.15. AT+TCPDISB

- Function: Connect/Disconnect TCP_B link
- Format:
 - ◆ Query
AT+TCPDISB<CR>
+ok=<sta><CR><LF><CR><LF>
 - ◆ Set
AT+ TCPDISB =<on/off><CR>
+ok<CR><LF><CR><LF>
- Parameters:
 - off: module will not try to establish link, that is, when module receive the command, it will disconnect and not connect again.
 - on: module will connect to server immediately.

This command will not be saved, default open after reset.

5.3.1.16. AT+TCPLKB

- Function: Query whether TCP_B link is established
- Format:
 - AT+ TCPLKB<CR>
+ok=<sta><CR><LF><CR><LF>
- Parameters
 - ✧ sta.: whether TCP_B link is established
 - on: established
 - off: not established

5.3.1.17. AT+WSSSID

- Function: Query/Set SSID of AP
- Format:
 - ◆ Query

```
AT+WSSSID<CR>
+ok=<ap's ssid><CR><LF><CR><LF>
```

◆ Set

```
AT+ WSSSID=<ap's ssid ><CR>
+ok<CR><LF><CR><LF>
```

➤ Parameters:

ap's ssid:SSID of AP, max 32 bytes

5.3.1.18. AT+WSKEY

➤ Function: Query/Set encryption parameters of STA

➤ Format:

◆ Query

```
AT+WSKEY<CR>
+ok=<auth, encry, key><CR><LF><CR><LF>
```

◆ Set

```
AT+ WSKEY=< auth, encry, key><CR>
+ok<CR><LF><CR><LF>
```

➤ Parameters:

✧ auth: authentication mode, including

OPEN
SHARED
WPAPSK
WPA2PSK

✧ encry: encryption, including

NONE: valid when “auth=OPEN”
WEP-H: valid when “auth=OPEN” or “SHARED”, in HEX password format
WEP-A: valid when “auth=OPEN” or “SHARED”, in ASCII password format
TKIP: valid when “auth= WPAPSK or WPA2PSK”
AES: valid when “auth= WPAPSK or WPA2PSK”

✧ key: password

When encry=WEP-H, password in HEX, 10 or 26 bytes
When encry=WEP-A, password in ASCII, 5 or 13 bytes
Others in ASCII code, greater than 8 bytes and less than 64 bytes

5.3.1.19. AT+WANN

➤ Function: Query/Set network parameters of STA

➤ Format:

◆ Query

```
AT+WANN<CR>
+ok=<mode, address, mask, gateway><CR><LF><CR><LF>
```

◆ Set

```
AT+ WANN=< mode, address, mask, gateway ><CR>
```

+ok<CR><LF><CR><LF>

- Parameters:
 - ✧ mode: network IP mode of STA
static: static IP
DHCP: dynamic IP
 - ✧ address: IP address of STA
 - ✧ mask: subnet mask of STA
 - ✧ gateway: gateway of STA

5.3.1.20. AT+WSMAC

- Function: Query/Set MAC address of STA
- Format:
 - ◆ Query
AT+WSMAC<CR>
+ok=<mac_address><CR><LF><CR><LF>
- Parameters:
 - mac_address: MAC address of STA, example: D8B0CFFF1234

5.3.1.21. AT+WSLK

- Function: Query the wireless link status of STA
- Format:
 - ◆ Query
AT+WSLK<CR>
+ok=<ret><CR><LF><CR><LF>
- Parameters:
 - ✧ ret
If no link, reply "Disconnected"
If link, reply "SSID(MAC) of AP"
If wireless is closed, reply "RF Off"

5.3.1.22. AT+WSLQ

- Function: Query the wireless signal strength of STA
- Format:
 - ◆ Query
AT+WSLQ<CR>
+ok=<ret><CR><LF><CR><LF>
- Parameters:
 - ✧ ret
If no link, reply "Disconnected"
If link, reply signal strength of AP

5.3.1.23. AT+WSCAN

- Function: Scan AP
 - Format:
 - ◆ Query
AT+ WSCAN<CR>
+ok=<LF><CR>Ch,SSID,BSSID,Security,Indicator<LF><CR><ap_site_1><LF><CR><ap_site_2><LF><CR><ap_site_3><LF><CR>...<ap_site_N><LF><CR><CR><LF>
 - Parameters:
 - ✧ ap_site_N: the AP site that scanned, format is <Ch,SSID,BSSID,Security,Indicator>
Ch: channel no. of WiFi network
SSID: SSID of router
BSSID: MAC address of router
Security: security mode of router
Indicator: signal strength
- Example: "11,TP_LINK_USR,D8:15:0D:C6:3E:14,WPA2PSK/AES,76"

5.3.1.24. AT+WSDNS

- Function: Query/Set DNS server address in STA mode, static
- Format:
 - ◆ Query
AT+WSDNS<CR>
+ok=<address><CR><LF><CR><LF>
 - ◆ Set
AT+ WSDNS =<address><CR>
+ok<CR><LF><CR><LF>
- Parameters:
 - address: DNS server address in STA

5.3.1.25. AT+LANN

- Function: Query/Set network parameters of AP
- Format:
 - ◆ Query
AT+LANN<CR>
+ok=<ipaddress,mask><CR><LF><CR><LF>
 - ◆ Set
AT+ LANN=< ipaddress,mask><CR>
+ok<CR><LF><CR><LF>
- Parameters:
 - ✧ ipaddress: IP address in AP mode
 - ✧ mask: subnet mask in AP mode

5.3.1.26. AT+WAP

- Function: Query/Set WiFi settings of AP
- Format:
 - ◆ Query
AT+WAP<CR>
+ok=< wifi_mode,ssid,channel ><CR><LF><CR><LF>
 - ◆ Set
AT+ WAP =<wifi_mode,ssid,channel ><CR>
+ok<CR><LF><CR><LF>
- Parameters:
 - ✧ wifi_mode: Wi-Fi mode, including
11B
11BG
11BGN (default)
 - ✧ ssid: SSID in AP mode
 - ✧ channel: Wi-Fi channel
Select AUTO or CH1~CH11, default CH6

5.3.1.27. AT+WKEY

- Function: Query/Set encryption of AP
- Format:
 - ◆ Query
AT+WKEY<CR>
+ok=<auth,encry,key><CR><LF><CR><LF>
 - ◆ Set
AT+ WKEY=< auth,encry,key><CR>
+ok<CR><LF><CR><LF>
- Parameters:
 - ✧ auth: authentication type, including
OPEN
WPA2PSK
 - ✧ encry: encryption type, including
 - ✧ NONE: valid when “auth=OPEN”
 - ✧ AES: valid when “auth=WPA2PSK”
 - ✧ key: password, in ASCII, less than 64bytes and greater than 8 bytes

5.3.1.28. AT+WALK

- Function: Query the MAC address of STA device, which linked to module
- Format:
 - ◆ Query

```
AT+WALK<CR>
+ok=<status><CR><LF><CR><LF>
```

- Parameters:
 - ✧ status: the MAC address of STA device, which linked to module
 - ✧ No Connection: no STA devices linked to module AP

5.3.1.29. AT+PLANG

- Function: Query/Set language of webpage
- Format:
 - ◆ Query
AT+PLANG<CR>
+ok=<language><CR><LF><CR><LF>
 - ◆ Set
AT+PLANG =<language><CR>
+ok<CR><LF><CR><LF>
- Parameters:
 - ✧ language: language of webpage
CN Chinese(default)
EN English

5.3.1.30. AT+DTDDIS

- Function: Open/Close function of send D2D registration packet
- Format:
 - ◆ Query
AT+DTDDIS<CR>
+ok=<status><CR><LF><CR><LF>
 - ◆ Set
AT+DTDDIS=<status><CR>
+ok<CR><LF><CR><LF>
- Parameters:
 - ✧ status:
on: open
off: close

Note: we no longer recommend this function now.

5.3.1.31. AT+DTDID

- Function: Query/Set registration ID of D2D
- Format:
 - ◆ Query
AT+DTDID<CR>

```
+ok=<id><CR><LF><CR><LF>
```

◆ Set

```
AT+DTDID=<id><CR>
```

```
+ok<CR><LF><CR><LF>
```

➤ Parameters:

id: registration ID, range from 1~65535

Note: we no longer recommend this function now.

5.3.1.32. AT+WRMID

➤ Function: Set module ID

➤ Format:

◆ Set

```
AT+ WRMID =<wrmid><CR><LF><CR><LF>
```

```
+ok<CR><LF><CR><LF>
```

➤ Parameters:

wrmid: set module ID, in 20 characters

5.3.1.33. AT+ASWD

➤ Function: Query/Set module search password

➤ Format:

◆ Query

```
AT+ ASWD <CR>
```

```
+ok=<aswd><CR><LF><CR><LF>
```

◆ Set

```
AT+ASWD =<aswd><CR><LF><CR><LF>
```

➤ Parameters:

aswd: module search password

5.3.1.34. AT+SMTLK

➤ Function: start Simplelink function

➤ Format:

◆ Query

```
AT+SMTLK<CR>
```

Smartlink function us used to connect module to router easily. When function on, module work in this mode, led lights quickly and waiting for the APP to push configuration information

5.3.1.35. AT+USERVER

➤ Function: Query user version and edit time

➤ Format:

AT+USERVER<CR>

+ok=<user_version,generated_time><CR><LF><CR><LF>

- Parameters:
 - ✧ user_version:
V1.1
 - ✧ generated_time: edit time
2014-08-15 10:15

5.3.1.36. AT+RPTMAC

- Function: Query whether report MAC
- Format:

AT+RPTMAC<CR>
+ok=<status><CR><LF><CR><LF>
- Parameters:
 - ✧ status:
ON: open
OFF: closed

5.3.1.37. AT+WRRPTMAC

- Function: Set whether report MAC
- Format:

AT+WRRPTMAC=<status><CR>
+ok<CR><LF><CR><LF>
- Parameters:
 - ✧ status:
ON: open
OFF: closed

6. Contact Us

Company: Jinan USR IOT Technology Limited
Address: Floor 11, Building1, No.1166 Xinluo Street, Gaoxin Distric, Jinan, Shandong, 250101, China
Tel: 86-531-55507297, 86-531-88826739
Web: <http://www.usriot.com>
Support : <http://h.usriot.com>
Email: sales@usriot.com

7. Disclaimer

This document provide the information of USR-C215 products, hasn't been granted any theintellectual property license by forbid speak or other ways either explicitly or implicitly. Except for the duty of sales conditions and conditional declarations, we don't take any other responsibilities. We don't warrant the products sales and use explicitly or implicitly, including particular purpose merchantability and marketability, the tort liability of any other patent right, copyright, intellectual property right. We may modify specification and description at any time without prior notice.

8. Update History

2016-04-29 Establish V1.0